



UNIVERSITÀ POLITECNICA DELLE MARCHE

FACOLTÀ DI INGEGNERIA

Corso di Laurea in Ingegneria Informatica e dell'Automazione

**Controllo Robusto Vincolato di Carroponti Mirato
alla Riduzione delle Oscillazioni Del Carico**

**A Robust Control Architecture for Minimizing the
Oscillations in the Fast Response of a Gantry Crane
Control System**

Relatore:
**Chiar.ma Prof.ssa Valentina
Orsini**

Candidato:
Pietro Bonsanto

Correlatore:
Prof. Leopoldo Jetto

Anno Accademico 2020-2021

Contents

| | | |
|----------|--|-----------|
| 1 | Cranes importance in Factories | 6 |
| 1.1 | Gantry Cranes Control Problem | 7 |
| 1.1.1 | Control Specifications | 7 |
| 1.2 | Control Techniques | 7 |
| 1.2.1 | Open Loop Techniques | 7 |
| 1.2.2 | Closed Loop Techniques | 8 |
| 1.2.3 | Hybrid Control Techniques | 10 |
| 1.2.4 | The Proposed Control Strategy: A Robust Feedback and Constrained Control | 11 |
| 1.2.5 | Problem Approach | 11 |
| 2 | Tools Used to Design the Control Law | 12 |
| 2.1 | Linear Matrix Inequalities | 12 |
| 2.2 | Schur Complement | 12 |
| 2.3 | Lyapunov's Theorem (D.T) | 12 |
| 2.4 | State Feedback Stabilization | 12 |
| 2.5 | Quadratic State Feedback Stabilization (D.T) | 13 |
| 2.6 | Output Feedback Observer Based Stabilization for a Polytopic Pro- cess (D.T) | 13 |
| 2.7 | Invariant Set and Invariant Ellipsoid | 16 |
| 2.8 | A Stabilizing constraints Setter State Feedback Control Law | 17 |
| 3 | Problem Setup | 18 |
| 3.1 | Process Model | 18 |
| 3.2 | Control Scheme | 20 |
| 3.3 | Bounded Parameters and Invariant Sets for Politopic Processes | 21 |
| 3.4 | Controller Design | 22 |
| 4 | Numerical Results | 24 |
| 4.1 | Quadratic Stabilization | 24 |
| 4.2 | Quadratic Stabilization fulfilling the constraint over the sway angle | 27 |
| 4.3 | Quadratic Stabilization Including the Constrained Sway Angle and the Constrained Control Effort | 30 |
| 5 | Conclusions | 35 |

List of Figures

| | | |
|---|---|----|
| 1 | Model of a Gantry Crane | 6 |
| 2 | Block diagram of open loop control strategy for a crane system. | 8 |
| 3 | Block diagram of a feedback control scheme. | 9 |
| 4 | Block diagram of an hybrid control scheme. | 10 |
| 5 | Gantry Crane Model | 19 |
| 6 | The Control Scheme Used | 20 |

| | | |
|----|---|----|
| 7 | Payload sway angle for different values of α using null initial conditions referring to S_1 simulation. | 25 |
| 8 | Controlled output $y_L(k)$ for different values of α using null initial conditions referring to S_1 simulation. | 25 |
| 9 | Payload sway angle $x_3(k)$ using different values of α with non-zero initial conditions referring to S_1 simulation. | 26 |
| 10 | Controlled output $y_L(k)$ using different values of α with non-zero initial conditions referring to S_1 simulation. | 26 |
| 11 | Payload sway angle $x_3(k)$ for many α values in the null initial conditions case, referring to S_2 simulation. | 28 |
| 12 | Forced output $y_L(k)$ for many α in the null initial conditions case, referring to S_2 simulation. | 28 |
| 13 | The sway angle $x_3(x)$ for different values of α using non-zero initial conditions, referring to S_2 simulation. | 29 |
| 14 | The forced output $y_L(k)$ for different values of α using non-zero initial conditions, referring to S_2 simulation. | 29 |
| 15 | The control effort $u(k)$ for Σ_f for different values of α referring to S_2 simulation, with null initial conditions | 30 |
| 16 | The control effort $u(k)$ for Σ_f for different values of α referring to S_2 simulation, with null initial conditions | 31 |
| 17 | The norm bounded control effort $u(k)$ for different values of α , referring to S_3 simulation with null initial conditions. | 32 |
| 18 | Norm bounded control effort $u(k)$ for different values of α and non-zero initial conditions, referring to S_3 simulation | 33 |
| 19 | Sway angle for different values of α and non-zero initial conditions, referring to S_3 simulation. | 34 |
| 20 | The controlled output for different values of α and non-zero initial conditions, referring to S_3 simulation. | 34 |

Sommario

Questa tesi si pone come obiettivo quello di proporre una soluzione semplice ed economica, al problema di controllo di carroponti. Come si vedrà in seguito, i carroponti sono dei sistemi molto complessi sia dal punto di vista del modello matematico, sia da un punto di vista di controllo di processo. Generalmente il problema di controllo di carroponti presenta, tra le specifiche più significative, lo spostamento del carico, tramite il moto del carrello, in una posizione desiderata e simultaneamente la minimizzazione delle oscillazioni del carico stesso. La tecnica di controllo presentata in questa tesi è ad 1 grado di libertà. Il controllore dinamico dall'uscita è progettato in modo tale da garantire non solo la stabilità a ciclo chiuso e il posizionamento esatto del carico ma anche il soddisfacimento di vincoli, fissati "a priori", su determinate variabili di stato (lo sforzo di controllo, l'angolo di oscillazione del carico). L'azione di controllo è determinata sulla base della sola misura del posizionamento del carrello comportando un notevole risparmio economico in termini di sensori. La realizzazione di tale azione di controllo richiede l'utilizzo di adeguati strumenti che sono appunto le disuguaglianze lineari matriciali (LMIs) e gli insiemi invarianti derivanti dalle condizioni di stabilità secondo Lyapunov. Le simulazioni effettuate confermano la validità dell'approccio proposto.

Abstract

This thesis has the scope to propose a simple and economic solution to the gantry cranes control problem. As it will be seen later, gantry cranes are such complex systems because of their mathematic model and because of the difficulties faced when dealing with the control problem. Commonly crane systems control problem requires the satisfaction of specifications such as the payload transition into the desired position by moving the cart, and simultaneously the payload oscillations minimization. The one proposed in this thesis is a one degree of freedom control technique. The dynamic output feedback controller is designed in order to grant not only closed loop stability and the exact payload positioning, but also the satisfaction of "a priori" fixed constraints on specific state variables (the control effort and the payload sway angle). The control effort is determined thanks to the measure of the payload position, implying money saving in terms of sensors. Its design requires adequate tools such as the Linear Matrix Inequalities and the invariant sets derived from the Lyapunov stability conditions. The numerical simulations also prove the proposed approach worthy.

1 Cranes importance in Factories

Cranes are widely used devices in factories to move heavy loads or hazardous material from a place to another; such machines are widespread especially in factories, shipyards and warehouses.

There are a lot of different type of cranes, such as overhead cranes, gantry cranes, boom cranes and rotating cranes. These machines can be diversified in terms of the number of Dof (degrees of freedom) which the support system offers in the suspension point. The problem when facing such complex systems is about the necessity to minimize the payload sway angle and to move it in the desired position by driving the crane itself. On one hand a failure when controlling the sway angle could imply problems also in the automation of the control system, on the other hand it could also provide serious damages either to the payload or to the environment.

The aim of this thesis, as said before, is to control gantry cranes, a particular type of cranes with an unusual structure. Gantry cranes provide in fact a free to move cart towards either right or left thanks to particular rails on a suspended girder, orthogonally built on a bridge supported by steel legs. Because of their structure, gantry cranes are largely used in shipyards and warehouses.

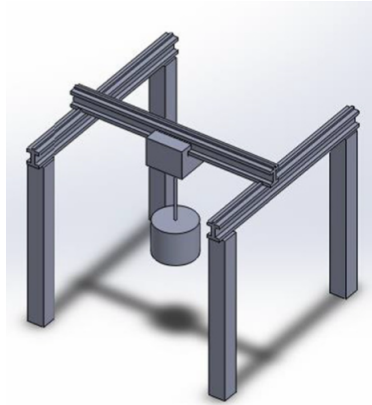

Figure 1: Model of a Gantry Crane

1.1 Gantry Cranes Control Problem

In the following sections some control techniques and specifications indications for the above described systems will be given.

1.1.1 Control Specifications

Gantry cranes control, in the most general case, includes a great amount of problems such as lots of specification to be fulfilled, in order to grant the desired behavior. In most of the cases cranes, and especially gantry cranes, are considered to be under-actuated systems, this because of the fact that they are given a lower number of actuators than the number of controlled variables; this in order to decrease their cost, their complexity, their dimensions and their weight. As a matter of fact this solution provides issues when trying to control them, even because of cranes complex dynamics.

As already mentioned, the principal control objective concerns achieving a correct trolley positioning in the desired location keeping the payload oscillation as little as possible, in order to move the crane in the minor possible time towards the destination with less or without sway. It is also important to remind that the payload itself behaves like a simple pendulum: by this, the operator might need to slow down and compensate for the crane's manoeuvres, in order to dampen out the payload oscillations that may interrupt the crane's performance; if a severe sway occurs, the operation could need to be paused until the payload stops swinging. Moreover, the hoisting functionality of the crane is one of the challenges faced by operators, as it also hugely affects the swinging of the payload.

1.2 Control Techniques

In order to achieve acceptable performances and to satisfy the control requirements, there are lots of control techniques devised for gantry cranes, divided into three categories: open loop techniques, closed loop techniques and closed and open loop combined techniques.

1.2.1 Open Loop Techniques

Open loop control schemes are widely used when dealing with gantry cranes due to their skills in facing sway angle problems. Easy to implement, such solutions don't require additional sensors to get a measure of the sway angle, and this certainly saves in terms of the cost; the main issue with this scheme is the high sensitivity towards external disturbances.

Input shaping

An application an open loop technique is the Input Shaping, based on feedforward control and implemented in order to minimize vibrations or oscillation induced movements of the cranes flexible structures. Thanks to this solution the system vibrations are reduced by convoluting the input command signal with a pulse sequence based on the natural frequencies and the damping ratios of the system. Below the issues about sensitivity towards disturbances and system parameters variations, this scheme needs the initial value of the sway angle to be null, otherwise it could cause

an in-load oscillation intensification. Another issue with this technique is that it is designed using system fixed parameters. This, when dealing either with time varying systems or systems with parameter uncertainty, in which the natural frequencies and the dampin ratios change, implies the necessity of an input shaping technique capable to adapt to such variation. This kind of solution is the so called adaptive input shaping.

Adaptive Input Shaping

As said before, most of the input shaping based techinques are based on fixed system parameters; this leads to issues when dealing either with time varing systems or systems with parameter uncertainty. In an effort to address the effects of playoad hoisting and the parametere uncertainties in crane systems, adaptive input shapers have been developed. A possible solution provides a techinque aimed to reduce systems vibrations based upon flexible mode frequency changes in order to cope with the parameter uncertainties. The problem with this scheme is that it can be used only when dealing with linear systems or linearized model of nonlinear systems.

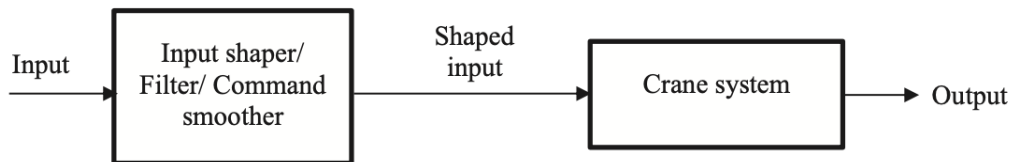

Figure 2: Block diagram of open loop control strategy for a crane system.

1.2.2 Closed Loop Techniques

The disadvantages coming from the use of open loop techniques consist in the uncapa-bility of ensuring external disturbances rejection and in an extremely high sensitivity towards parameter variations; in order to dampen out this lack closed loop schemes are introduced. These schemes allow the system to modify his performances basing on the desired output behavior: they use the measure and the estimation of the internal state to reduce oscillations and achieve an optimal trolley positioning.

PID Controllers

One of the most commonly used linear feedback control scheme for gantry cranes is based on the Proportional Integrative Derivative controller (PID). Literature provides a several amount of methods investigated, including root locus technique; furthermore, there are also controllers only based on Proportional and Derivative action (PD) with the scope to control the sway angle, thanks to their skill in opposing oscillation issues.

In most of the cases PID controllers are implemented with the aid of other control techniques, or by using two PID type controllers to control the position and the load's sway.

Optimal Control

Optimal Control is known as a strategy in which a control signal optimizes a certain cost index. The control strategy was first introduced as and open loop

scheme in order to design an optimal sequence control. There are two optimal control strategies regularly applied on industries:

- Linear Quadratic Gaussian, widely implemented in order to reduce gantry cranes sway angle;
- Model Predictive Control, which has become one of the most popular multi-variable control algorithm due to its advantages when dealing with constraints. Most of its implementation focus on the control of the trolley positioning and on the reduction of the sway angle.

Fuzzy Logic Controller

Fuzzy logic based controllers (FLC) are widely applied thanks to their capability to adapt to control systems and mainly because it isn't needed to know the exact model of the controlled object due to their intelligent method. In fact, as the systems became more complex, such as gantry cranes with nonlinearities, it was hard to obtain the mathematical model. Hence, the FLC has a benefit, as it replaces the role of a mathematical model with a fuzzy model, based on the rules constructed in an if-then format. What's more, such controllers are also capable to handle unstable and complex machines, nonlinear systems and optimal control problems. A FLC has been widely used in order to control the trolley positioning and the sway angle using robust feedback controllers, eventually with the aid of sensors.

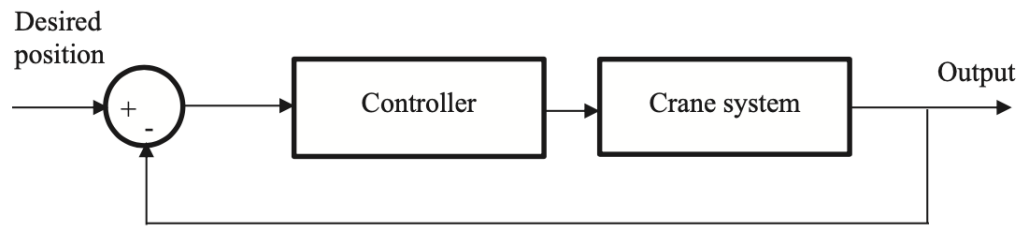

Figure 3: Block diagram of a feedback control scheme.

1.2.3 Hybrid Control Techniques

On one hand, open loop schemes hereby presented are extremely sensitive towards parameters variation, external disturbances and payload oscillation frequency. Moreover, when dealing with input shaping technique, it is required for the initial sway angle to be 0, else it could cause oscillations intensification. Despite these drawbacks, this strategy doesn't need sensors, allowing to decrease the cost. On the other hand, closed loop control schemes are less sensitive towards parameters variations and external disturbances; nevertheless such a scheme needs lots of sensors due to establish the trolley position and the sway angle, which leads to an increase in term of the cost. Moreover, in the case of feedback control schemes, problems given by instability and disturbances increase, implying many risks for a control system as the gantry crane. Another issue with FB controllers is about a delay in the feedback loop : an example could be the determination of the payload sway angle which is required prior to the action of the control scheme in order to dampen out oscillations. Aiming to deal with the necessity of keeping low costs with the one of granting steady-state good performances, some hybrid techniques have been designed, combining several feedback control schemes along with an input shaper. This combination allows the controller to act in two different ways:

1. A feedback scheme allows to control the trolley position and ensures disturbances rejection;
2. An input shaping open loop scheme reduces the payload oscillations.

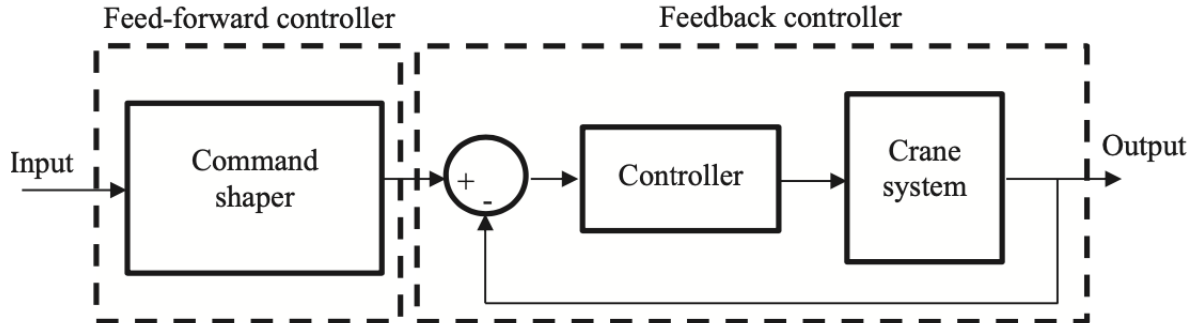

Figure 4: Block diagram of an hybrid control scheme.

1.2.4 The Proposed Control Strategy: A Robust Feedback and Constrained Control

As aforementioned, this thesis presents a gantry crane linearized model feedback control scheme. A linearized model is introduced in order to apply the linear control knowledge. By choosing this scheme, the control system will be granted all of the advantages feedback control provides, such as disturbances rejection, low parameters variations sensitivity, without the necessity to add additional sensors in order to get the measure of the sway angle and of the velocity signals, decreasing the costs. All of this thanks to an observer based feedback controller which provides an estimation of all the state variables. Furthermore, the controller is robustly designed in order to grant closed loop stability and the constraints satisfaction on the state variables for every payload value in a fixed uncertainty interval. A preliminar linearization is needed: in fact the relationship between the cart position and the sway angle is nonlinear.

1.2.5 Problem Approach

Given a linearized and discretized gantry crane model, endowed with an internal model of constant signals, according to the namesake principle, a discrete time observer based feedback controller is designed, in order to ensure quadratic stability to the closed loop system. The observer provides an estimation of the sway angle making the respective sensor superfluous, while the internal model grants the payload positioning into the desired point. The control strategy presented is divided in two steps:

- This first step is about finding the observer gain matrix L ;
- Once the L matrix is determined, the feedback controller gain matrix is computed by using at first a transformation matrix and then applying some sort of separation principle. The gain matrix is designed to grant quadratic stability to the closed loop system and the fulfillment of constraints on the state variables, using the required LMIs, as it will be clear soon.

The controller design procedure endowed with the constant signals internal model is based on the observer design and is developed in steps: a first step will require the fulfillment of quadratic stability for the closed loop system, then it will be added a constraint over the sway angle; in the end it will be granted quadratic stability to the closed loop system achieving also the fulfillment of constraints over the sway angle and the control effort.

2 Tools Used to Design the Control Law

This section presents some preliminar results of control theory, needed to comprehend important following steps.

2.1 Linear Matrix Inequalities

Linear Matrix Inequalities (LMI) are an useful tool to design robust controllers. Strictly connected to Lyapunov's theory for dinamical systems, they are defined as follows:

$$F(x) := F_0 + \sum_{i=1}^N x_i F_i > 0, F_i = F_i^T \in \mathbb{R}^{m \times m}, x \in \mathbb{R}^n$$

2.2 Schur Complement

It turns a nonlinear inequality into a linear inequality. Given the matrixes $Q = Q^T > 0, R = R^T > 0$

$$\begin{pmatrix} Q & S \\ S^T & R \end{pmatrix} < 0 \iff Q < 0, R - S^T Q^{-1} S < 0$$

$$\begin{pmatrix} Q & S \\ S^T & R \end{pmatrix} < 0 \iff R < 0, Q - S R^{-1} S^T < 0$$

2.3 Lyapunov's Theorem (D.T)

Lyapunov's theorem states that given a dynamic system $x(k+1) = Ax(k)$, the origin is an asimptotically stable equilibrium point if and only if

$$\exists Q = Q^T > 0 : A^T Q A - Q < 0$$

2.4 State Feedback Stabilization

The problem of state feedback stabilization can be solved using Lyapunov's theorem. The problem consists in finding a control law $u = -Kx$ to grant stability to the closed loop system. Using LMIs, one has $x(k+1) = (A - BK)x(k)$ is stable if

$$\exists Q = Q^T > 0 : (A - BK)^T Q (A - BK) - Q < 0$$

By using Schur complement and defining $KY = Q$, one has:

$$\begin{pmatrix} -Q & AQ - BY \\ QA^T - Y^T B^T & -Q \end{pmatrix} < 0$$

The gain matrix K defining the control law is $K = YQ^{-1}$

2.5 Quadratic State Feedback Stabilization (D.T)

If the dynamical matrix is affected by parameter uncertainty, the problem of stabilization is called quadratic stabilization: in this case the dynamical matrix is denoted as $A(\alpha)$, where α identifies a vector of linear independent parameters joining the matrix, defined on an uncertainty domain. The notation will be the following:

$$x(k+1) = A(\alpha)x, \alpha = \begin{pmatrix} p_1 \\ \vdots \\ p_l \end{pmatrix}, p_i \in [p^-, p^+]$$

Where p^- and p^+ are the uncertainty domain extremities of the uncertain parameter p . This uncertain parameter can be represented as linear combination of the uncertainty domain extremities:

$$p = \alpha p^- + (1 - \alpha)p^+, \alpha \in [0, 1]$$

The simplex is defined as follows:

$$\Lambda_N = \left\{ \alpha \in \mathbb{R}^N, \sum_{i=1}^N \alpha_i = 1, \alpha_i \geq 0 \right\}$$

α is the vector containing the coefficients of the convex combination.

It is said that the system $x(k+1) = A(\alpha)x + Bu$ is quadratically stabilizable if

$$\exists Q = Q^T > 0 : (A(\alpha) + BK)^T Q (A(\alpha) + BK) - Q < 0, \forall \alpha \in \Lambda_N$$

The main issue when dealing with polytopic uncertainty affected matrix is that it is impossible to solve the LMIs for the matrix $A(\alpha)$, because one gets infinite conditions. The solution being adopted here involves using the so called vertices conditions: instead of solving the LMIs for all α values, it is enough to solve them in the polytope vertices. In this case the vertices conditions, using Schur complement, are:

$$\exists Q = Q^T > 0 : \begin{pmatrix} -Q & A_i Q \\ Q A_i^T & -Q \end{pmatrix} < 0, \forall i \in [1 \dots N]$$

2.6 Output Feedback Observer Based Stabilization for a Polytopic Process (D.T)

Given the process

$$\begin{cases} x(k+1) = A(\alpha)x(k) + Bu(k), A(\alpha) = \sum_{i=1}^N \alpha_i A_i, \alpha_i \in \Lambda_N \\ y(k) = Cx(k) \end{cases}$$

If the condition of reachability for the pair $(A(\alpha), B)$ and the condition of observability for the pair $(A(\alpha), C)$ are satisfied $\forall \alpha \in \Lambda_N$, the observer will be described as follows:

$$\begin{cases} \xi(k+1) = \bar{A}\xi(k) + Bu(k) + L(y(k) - C\xi(k)) \\ u(k) = -K\xi(k) \end{cases}$$

Where \bar{A} denotes the nominal process matrix, defined as $\bar{A} = \frac{\sum_{i=1}^N A_i}{N}$. The space state representation of the closed loop system is:

$$\begin{pmatrix} x(k+1) \\ \xi(k+1) \end{pmatrix} = \begin{pmatrix} A(\alpha) & -BK \\ LC & \bar{A} - BK - LC \end{pmatrix} \begin{pmatrix} x(k) \\ \xi(k) \end{pmatrix}$$

By using a transformation matrix one has:

$$\begin{pmatrix} x(k) \\ x(k) - \xi(k) \end{pmatrix} = \begin{pmatrix} I & 0 \\ I & -I \end{pmatrix} \begin{pmatrix} x(k) \\ \xi(k) \end{pmatrix}$$

$$\begin{pmatrix} x(k+1) \\ x(k+1) - \xi(k+1) \end{pmatrix} = \begin{pmatrix} A(\alpha) - BK & BK \\ A(\alpha) - \bar{A} & \bar{A} - LC \end{pmatrix} \begin{pmatrix} x(k) \\ x(k) - \xi(k) \end{pmatrix}$$

In this case it is not possible to apply the separation principle, due to the fact that the dynamical matrix isn't lower triangular; so it is needed to proceed in another way, in two steps:

- Step 1: design of the matrix L such that $(A(\alpha) - LC)$ is quadratically stable;
- Step 2: Design of the matrix K which defines the control law u(t), using the extended matrixes:

$$\begin{pmatrix} \hat{A} - BK & LC \\ A(\alpha) - \hat{A} & A(\alpha) - LC \end{pmatrix} = \begin{pmatrix} \hat{A} & LC \\ A(\alpha) - \hat{A} & A(\alpha) - LC \end{pmatrix} - \begin{pmatrix} B \\ 0 \end{pmatrix} (K \ 0) = \tilde{A} - \tilde{B}\tilde{K}$$

At this point the problem is solved by setting suitable LMIs:

- The required LMIs for the design of L are:

$$\exists S = S^T > 0 : \begin{pmatrix} -S & SA_i - ZC \\ A_i^T S - Z^T C^T & -S \end{pmatrix} < 0, \forall i \in [1 \dots N]$$

dove $L = ZS^{-1}$

- Whereas for \tilde{K} :

$$\begin{pmatrix} -Q & Q\tilde{A}_i^T + Y^T\tilde{B}^T \\ \tilde{A}_i Q + \tilde{B}Y & -Q \end{pmatrix} < 0, \forall i \in [1 \dots N]$$

Where it is needed to give an appropriate structure to the matrices:

$$Q = \begin{pmatrix} Q_1 & 0 \\ 0 & Q_2 \end{pmatrix} > 0, Q_1 = Q_1^T > 0, Q_2 = Q_2^T > 0,$$
$$Y = (Y_1 \ 0), \tilde{K} = (K \ 0) = YQ^{-1} = (Y_1 Q_1^{-1} \ 0)$$

2.7 Invariant Set and Invariant Ellipsoid

From the Lyapunov theory it is well known that, given a dynamic system

$$x(k+1) = Ax(k), x \in \mathbb{R}^n$$

it is defined an invariant set

$$M \subseteq \mathbb{R}^n$$

if

$$\forall x(0) \in X \implies x(k+1) \in X$$

holds.

In order to design an appropriate control law, it is needed to enlarge the definition, introducing Invariant Ellipsoids.

A reachable set for norm bounded inputs is used to study the effect of external parameters disturbances or to develop controllers ensuring their rejection in steady-state. The most spread method to calculate the reachable set for a discrete time system consists in finding the regions the state can reach recursively. However, such a strategy presents diverse issues; it is needed to approximate the reachable set from the outside with a set with only few parameters. The reachable set for bounded inputs is approximated with an ellipsoidal invariant set, due to the fact that it covers the reachable set and it is represented by few parameters.

Considering a discrete time system of the type

$$x(k+1) = Ax(k) + B\omega(k), k \in \mathbb{Z}$$

con $A \in \mathbb{R}^{n \times n}, B \in \mathbb{R}^{n \times m}$ e $x \in \mathbb{R}^n, \omega \in \mathbb{R}^m$. A set X is defined invariant for a pair (A,B) if it satisfies

$$x \in X, \|\omega\| \leq 1 \implies Ax + B\omega \in X$$

Suppose (A,B) is a pair of a discrete time system, and $A \in \mathbb{R}^{n \times n}, B \in \mathbb{R}^{n \times m}$. For a positive definite matrix $P \in \mathbb{R}^{n \times n}$, the ellipsoid $\{x \in \mathbb{R}^n : x^T Q x \leq 1\}$ is an invariant set of this pair only if exists $\alpha \in [0, 1 - \rho(A)^2]$ satisfying

$$\begin{pmatrix} A^T P A - (1 - \alpha)P & A^T P B \\ B^T P A & B^T P B - \alpha I \end{pmatrix} \leq 0$$

2.8 A Stabilizing constraints Setter State Feedback Control Law

Invariant ellipsoids are chosen for their connection with LMIs. Moreover, using invariant sets while designing the controller allows to set constraints over the state variables.

Given the process

$$\begin{aligned}x(k+1) &= Ax(k) + Bu(k) + B_\omega\omega(k) \\y(k) &= Cx(k)\end{aligned}$$

con

$$x \in \mathbb{R}^n, u \in \mathbb{R}^m, y \in \mathbb{R}^p, \omega \in \mathbb{R}^{n_\omega}$$

considering euclidean norm bounds on the control input and on the output:

$$\|u\|_2 \leq u_{max}$$

$$\|y\|_2 \leq y_{max}$$

furthermore, even the external input vector is norm bounded:

$$\omega^T \omega \leq 1$$

defined an invariant ellipsoid as follows:

$$E = \{x : x^T Q x \leq 1\}$$

with $Q \in \mathbb{R}^{n \times n}$ it is possible to determine a stabilizing control law of the type $u = -Kx$ fulfilling each constraint, which simultaneously ensures the satisfaction of each bound, while maximizing the invariant ellipsoid by solving the following semidefinite programming problem:

$$\begin{aligned}&\begin{pmatrix} Q^{-1} & 0 & \alpha Q^{-1} & Q^{-1}A_i^T + Y^T B_i^T \\ 0 & \alpha I & 0 & B_\omega^T \\ \alpha Q^{-1} & 0 & \alpha Q^{-1} & 0 \\ A_i Q^{-1} + B_i Y & B_\omega & 0 & Q^{-1} \end{pmatrix} \geq 0 \\&\begin{pmatrix} Q^{-1} & Y^T \\ Y & u_{max}^2 I \end{pmatrix} \geq 0 \\&\begin{pmatrix} Q^{-1} & (A_i Q^{-1} + B_i Y)^T C^T \\ C(A_i Q^{-1} + B_i Y) & y_{max}^2 I - C B_\omega B_\omega^T C^T \end{pmatrix} \geq 0 \\&\forall i \in [1 \dots N]\end{aligned}$$

The gain matrix K has the form $K = YQ^{-1}$.

3 Problem Setup

3.1 Process Model

In this section it is made reference to the gantry crane in Fig.5, where m_c is the trolley mass, l is the rope length, m_L is the payload mass, x_1 is the cart position, x_3 is the sway angle and u is the force applied to the cart. Moreover, it will be assumed $x_2 = \dot{x}_1$ and $x_4 = \dot{x}_3$. As mentioned before, the relationship between the payload position and the sway angle is nonlinear, so it is needed a linearization: assuming the sway angle is small, it can be desumed that $\cos(x_3) \approx 1$, $\sin(x_3) \approx x_3$, $\sin^2(x_3) \approx 0$ and $x_4^2 \approx 0$. The linearized state space model will have the following state vector:

$$\mathbf{x}(t) = \begin{pmatrix} x_1(t) \\ x_2(t) \\ x_3(t) \\ x_4(t) \end{pmatrix}$$

Before starting designing the controller, the process requires to be discretized. After rejecting the Euler method, it has been chosen to use the zero order hold (ZOH) and a sampler. By denoting with $y_L(k)$ the cart position, one has

$$y_L(k) = x_1 + l \sin(x_3) \approx x_1 + l x_3 = \begin{pmatrix} 1 & 0 & l & 0 \end{pmatrix} x(k)$$

The state space model of the linearized and discretized process obtained is:

$$\begin{aligned} x(k+1) &= Ax(k) + Bu(k) \\ y_L(k) &= C_L x(k) \\ y_m(k) &= C_m x(k) \end{aligned}$$

where

$$\begin{aligned} A &= \begin{pmatrix} 0 & 1 & 0 & 0 \\ 0 & 0 & \frac{m_L}{m_c} g & 0 \\ 0 & 0 & 0 & 1 \\ 0 & 0 & -\frac{m_L + m_c}{m_c l} g & 0 \end{pmatrix}, B = \begin{pmatrix} 0 \\ \frac{1}{m_c} \\ 0 \\ -\frac{1}{m_c l} \end{pmatrix} \\ C_L &= \begin{pmatrix} 1 & 0 & l & 0 \end{pmatrix} \\ C_m &= \begin{pmatrix} 1 & 0 & 0 & 0 \end{pmatrix} \end{aligned}$$

$y_L(k) \in \mathbb{R}^q$, $q = 1$ is the controlled output, $y_m(k) \in \mathbb{R}^s$, $s = 1$ is the measured output and $u(k) \in \mathbb{R}^m$, $m=1$ is the control effort. Note that the controlled output $y_L(k)$ (the payload position) does not coincide with the measured output $y_m(k) = x_1(k)$ (the trolley position) because it is assumed that the sway angle isn't measured. To deal with this, a dynamic output feedback controller will be designed using the virtual measure $\hat{y}_L(k) = x_1(k) + l \xi_3(k)$, where $\xi_3(k)$ will be provided by the observer. The following parameters values are assumed: $l = 10m$, $m_c = 1000$ kg e $g = 9.81m/s^2$. The payload mass m_L takes values in $[1500, 2000]$ kg. As a consequence, the polytopic uncertainty affected process version will have the following dynamical matrix:

$$A(\alpha) \in \mathcal{A} = \left\{ A(\alpha) = \sum_{i=1}^N \alpha_i A_i, \alpha_i \geq 0, \sum_{i=1}^N \alpha_i = 1 \right\}$$

with

$$A_1 = \begin{pmatrix} 0 & 1 & 0 & 0 \\ 0 & 0 & 14.7150 & 0 \\ 0 & 0 & 0 & 1 \\ 0 & 0 & -2.4525 & 0 \end{pmatrix}, A_2 = \begin{pmatrix} 0 & 1 & 0 & 0 \\ 0 & 0 & 19.6200 & 0 \\ 0 & 0 & 0 & 1 \\ 0 & 0 & -2.9430 & 0 \end{pmatrix}$$

It can easily be verified that the linearized polytopic uncertainty affected gantry crane model $\Sigma \equiv (A(\alpha), B, C_m, C_L)$ satisfies the following properties:

- Σ can be quadratically stabilized with an output feedback dynamic controller;
- The triplet $(A(\alpha), B, C_L)$ has no transmission zeros in $z = 1$ in the Z plane $\forall \alpha \in \Lambda_2$.

The second property also guarantees that the quadratic controller ensures null steady-state tracking error thanks to the constant signals internal model.

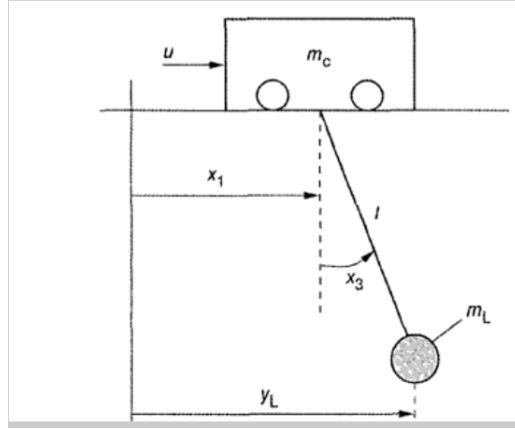

Figure 5: Gantry Crane Model

3.2 Control Scheme

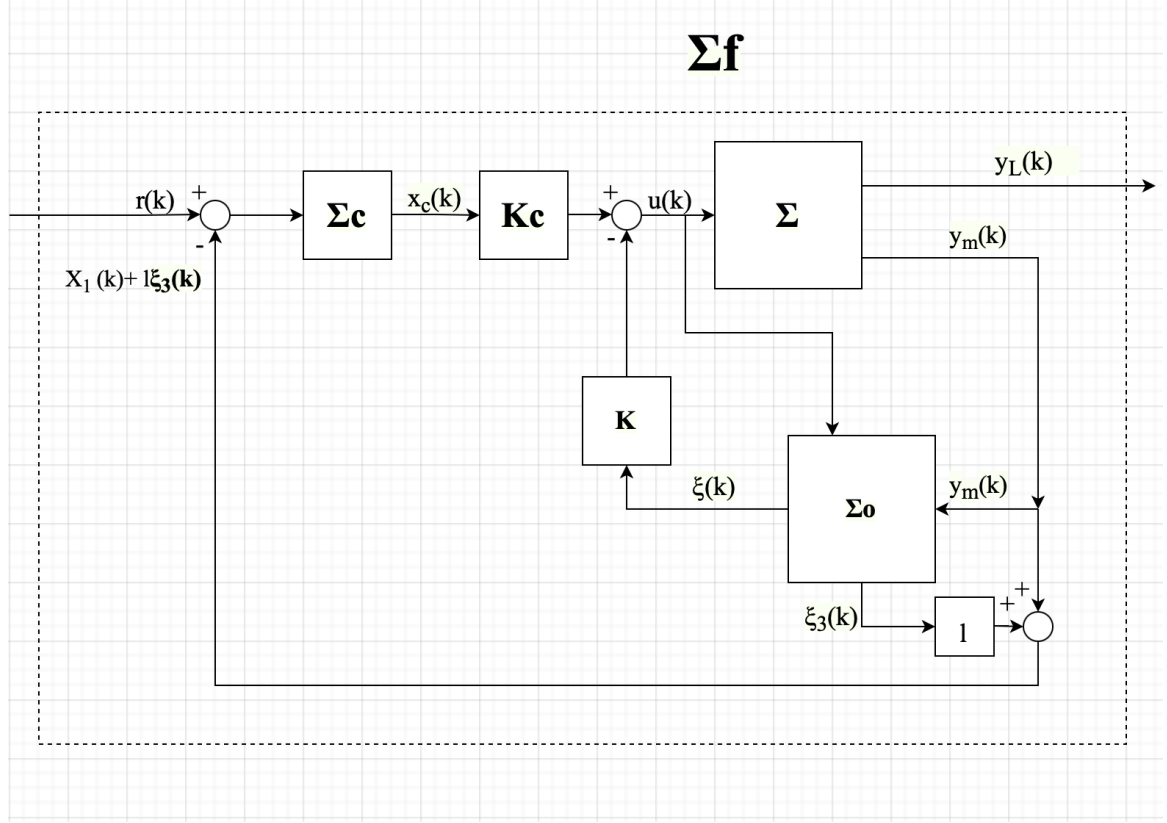

Figure 6: The Control Scheme Used

The 1DoF control scheme proposed in this thesis is shown in Fig.6. Σ_f denotes the feedback loop to the polytopic linearized model $\Sigma \equiv (A(\alpha), B, C_m, C_L)$ with a dynamic output quadratic stabilizing feedback controller based on the observer Σ_o of $x(k)$ and on the constant signals internal model Σ_c . The observer Σ_o has the form

$$\xi(k+1) = \bar{A}\xi(k) + Bu(k) + L(y_m(k) - C_m\xi(k))$$

Where $\xi(k) \in \mathbb{R}^n$ and $\bar{A} = \frac{\sum_{i=1}^N A_i}{N}$ is the nominal dynamical matrix for Σ . Recalling that $\hat{y}_L(t) = x_1(t) + l\xi_3(t)$ is the virtual measure of the controlled output provided by Σ_o , the state space representation of Σ_c is

$$x_c(k+1) = A_c x_c(k) + B_c (r(k) - \hat{y}_L(k)) \quad (1)$$

where $A_c = B_c = I_q$, $x_c \in \mathbb{R}^{n_c=q}$. The input $u(k)$ forcing Σ is $u(k) = -K\xi(k) + K_c x_c(k)$. Denoting the extended state vector $x_e(k) = (x^T(k), x_c^T(k), \xi^T(k))^T$, the triplet $(A_f(\alpha), B_f, C_f)$ of the closed loop system Σ_f is:

$$x_e(k+1) = \begin{pmatrix} A(\alpha) & BK_c & -BK \\ -B_c C_m & A_c & -B_c \begin{pmatrix} 0 & 0 & l & 0 \end{pmatrix} \\ LC_m & BK_c & \bar{A} - LC_m - BK \end{pmatrix} x_e(k) + \begin{pmatrix} 0 \\ B_c \\ 0 \end{pmatrix} r(k)$$

$$y_L(k) = (C_L \ 0 \ 0) x_e(k)$$

where, as for the process dynamical matrix $A(\alpha)$, also

$$A_f(\alpha) \in \mathcal{A}_f = \left\{ A_f(\alpha) = \sum_{i=1}^2 \alpha_i A_{fi}, \alpha_i \geq 0, \sum_{i=1}^2 \alpha_i = 1 \right\}$$

The problem of designing a quadratically stabilizing controller is divided into three subproblems:

1. Design of the quadratically stabilizing controller;
2. Design of the quadratically stabilizing controller with a bounded sway angle;
3. Design of the quadratically stabilizing controller with a bound on the sway angle and on the control effort.

3.3 Bounded Parameters and Invariant Sets for Polytopic Processes

An invariant feasible set for Σ_f is a convex set X containing the origin such that, for every $r(k)$ which satisfies

$$r^T(k)r(k) = \|r(k)\|_2^2 \leq \gamma, \forall k > 0, \gamma > 0$$

one has $x(k) \in X \implies A_f(\alpha)x(k) + B_f r(k) \in X, \forall \alpha \in \Lambda_2$ and satisfying the following constraint:

$$|x_3(k)| = \|x_3(k)\|_2 \leq \bar{x}_3$$

where x_3 is the third component of the state vector, the sway angle, while \bar{x}_3 is its upper bound, γ is the maximum allowable for $r(k)$. In this case X is an ellipsoid defined as $\varepsilon(P, \gamma) = \{x(k) : x^T(k)Px(k) \leq \gamma\}$, with $P = Q^{-1}$, symmetric and positive definite.

3.4 Controller Design

As aforementioned, this thesis aims to design a dynamic output quadratically stabilizing controller in order so fulfill the control requirements. In addition to the correct steady-state tracking for constant signals, granted by the internal model, the specifications to satisfy are:

1. Quadratic stability of Σ_f ;
2. The existence of an invariant set X such that $x_e(k) \in X \implies A_f(\alpha)x_e(k) + B_f r(k) \in X, \forall \alpha \in \Lambda_2$, as well as the fulfillment of constraints over the control effort and the sway angle for every feasible $r(k)$ of Σ_f .

Using the usual transformation matrix on the state vector $x_e(k)$ and choosing as new vector $x_f(k) = (\xi^T(k), x_c^T(k), x^T(k) - \xi^T(k))^T$ the closed loop system state space representation is:

$$x_f(k+1) = \begin{pmatrix} \bar{A} - BK & BK_c & LC_m \\ -B_c(C_m + C_L) & A_c & -B_c C_m \\ A(\alpha) - \bar{A} & 0 & A(\alpha) - LC_m \end{pmatrix} x_f(k) + \begin{pmatrix} 0 \\ B_c \\ 0 \end{pmatrix} r(k)$$

$$y(k) = (C_L \ 0 \ C_L) x_f(k)$$

Since it is needed to set a bound over the third component of the process state vector, it is needed to extract it from the extended state vector $x_f(k)$.

In order to do this two row vectors are introduced, defined as: $I_z = (0 \ 0 \ 1 \ 0)$ and $C_z = (I \ 0 \ I)$ such that one has:

$$x_3(k) = (0 \ 0 \ 1 \ 0) (I \ 0 \ I) x_f(k)$$

By observing the closed loop dynamical matrix, it can be noticed it isn't a lower triangular matrix so it isn't possible to apply the separation principle; so it is proposed a two step procedure:

- Step 1: Design of the observer gain matrix L such that $A(\alpha) - LC_m$ is quadratically stable $\forall \alpha \in \Lambda_2$;
- Step 2: Once L is fixed, the feedback gain matrix \tilde{K} defining the control law can be computed observing that the polytopic uncertainty affected dynamical matrix of the closed loop system $A_f(\alpha)$ can be rewritten as $A_f(\alpha) = \tilde{A}(\alpha) + \tilde{B}\tilde{K}$, with

$$\tilde{A}(\alpha) = \begin{pmatrix} \bar{A} & 0 & LC_m \\ -B_c(C_m + C_L) & A_c & -B_c C_m \\ A(\alpha) - \bar{A} & 0 & A(\alpha) - LC_m \end{pmatrix}, \tilde{B} = \begin{pmatrix} B \\ 0 \\ 0 \end{pmatrix}$$

As a consequence, the controller design problem can be seen as the problem to determine the matrix \tilde{K} in order to satisfy:

- $\Sigma_f = (A_f(\alpha), B_f, C_f) \equiv (\tilde{A}(\alpha) + \tilde{B}\tilde{K}, B_f, C_f)$ quadratically stable $\forall \alpha \in \Lambda_2$;

- Fulfillment of the constraint over x_3 for every initial condition $x_f(0) \in X$, $\forall \alpha \in \Lambda_2$ and for every $r(k)$ satisfying

$$\|r(k)\|_2^2 \leq \gamma, \forall k > 0, \gamma > 0$$

Given the pair $(\tilde{A}(\alpha), \tilde{B})$ and defining $\eta = \gamma^{-1}$, a solution can be found by solving the following semidefinite programming problem:

$$\begin{pmatrix} Q & 0 & \beta Q & Q\tilde{A}_i^T + Y^T\tilde{B}^T \\ 0 & \beta I & 0 & B_f^T \\ \beta Q & 0 & \beta Q & 0 \\ \tilde{A}_i Q + \tilde{B}Y & B_f & 0 & Q \end{pmatrix} \geq 0, i = 1, 2$$

$$\begin{pmatrix} Q & Y^T \\ Y & \bar{u}_{max}^2 \eta \end{pmatrix} \geq 0$$

$$\begin{pmatrix} Q & (Q\tilde{A}_i^T + Y^T\tilde{B}^T)C_z^T I_z^T \\ I_z C_z (\tilde{A}_i Q + \tilde{B}_i Y) & \bar{x}_3^2 \eta - I_z C_z B_f B_f^T C_z^T I_z^T \end{pmatrix} \geq 0, i = 1, 2$$

using the variables $0 < \beta < 1$, $Q = Q^T = \text{diag}\{Q_1, Q_2\} \in \mathbb{R}^{n \times n}$, $n = 2n + 1$ e $Y = (Y_1 \ 0) \in \mathbb{R}^{m \times n}$, $Y_1 \in \mathbb{R}^{m \times (n+1)}$, in the vertices

$$\tilde{A}_i = \begin{pmatrix} \bar{A} & 0 & LC_m \\ -B_c(C_m + C_L) & A_c & -B_c C_m \\ A_i - \bar{A} & 0 & A_i - LC_m \end{pmatrix}, \forall i = 1, 2.$$

If there exists a solution to the LMIs, the stabilizing controller gain matrix is $\tilde{K} = YQ^{-1} = (Y_1 Q_1^{-1} \ 0)$. The maximum feasible value for $r(k)$ is $\gamma = \eta^{-1}$ and the maximum invariant set $X \equiv \varepsilon(P, \gamma)$, with $P = Q^{-1}$, is found for Σ_f .

Note: The presence of β makes the LMI a BMI, which can be turned into an LMI by doing a gridding over the interval $(0, 1)$ where β is defined. Moreover, the η variable is fixed, and its value equals the payload positioning chosen value ($\eta = 1$).

4 Numerical Results

The results of the three numerical simulations of Σ_f are reported in this section. For each simulation the following parameters values are assumed: $\eta = 1$, $\beta = 0.001$ and $\bar{x}_3 = 0.03$. It is also important to recall that the payload mass m_L takes values in the interval $[1500, 2000]$ kg. Referring to the gantry crane model shown in section 3.1, the control scheme hereby proposed is designed in order to take the controlled output $y_L(t)$, (the payload position), from 0 to 1 achieving a perfect unit step steady-state tracking. Furthermore, $\alpha \in \Lambda_2$ will assume the following values for each simulation:

- $\alpha_1 = (0.8 \ 0.2)^T$
- $\alpha_2 = (0.6 \ 0.4)^T$
- $\alpha_3 = (0.4 \ 0.6)^T$
- $\alpha_4 = (0 \ 1)^T$
- $\alpha_5 = (0.2 \ 0.8)^T$

In addition, each of the three simulation has been conducted using at first null initial conditions, with $x_f(0) = (\xi^T(0), x_c^T(0), x^T(0) - \xi^T(0))^T = (0 \ 0 \ 0 \ 0 \ 0 \ 0 \ 0 \ 0 \ 0 \ 0)^T$, then using non-zero initial condition, still belonging to the invariant set: $x_f(0) = (\xi^T(0), x_c^T(0), x^T(0) - \xi^T(0))^T = (0 \ 0 \ 0 \ 0 \ 0 \ 0 \ 0 \ 0.001 \ 0)$

To be more specific, $x_3(0) = 0.001$ has been chosen to be an initial non-zero sway angle value, in order to simulate possible initial disalignment between the payload and the cart. In order to make the presentation simpler, the three simulations will be identified in the reported graphics as S_1, S_2, S_3 , respectively representing the simple quadratic stabilization, the norm bounded sway angle quadratic stabilization and the norm bounded sway angle and control effort quadratic stabilization. *Note:* when reporting the matrix Q defining the invariant set, in order to save space it has been decided to write the elements until the third decimal digit. This is the reason why all the elements containig zeros until (and even below) that digit have been written keeping the established number of digits, in order to be diversified from the other null elements.

4.1 Quadratic Stabilization

The first of the three simulations is the one requiring quadratic stabilization only. Using LMIs presented in section 2.5, the following matrices have been found: $L = (1.1176 \ 3.8770 \ 0.5754 \ -0.2144)^T$, $\tilde{K} = 10^8 (0.1610 \ 0.1412 \ 1.4218 \ 1.3998 \ -0.0010 \ 0 \ 0 \ 0 \ 0)$

After checking the fulfillment of the quadratic stabilization requirement, the payload sway angle and the controlled output have been computed, in order to check the null steady state tracking error for different values of α , as depicted in Figure 7 and 8.

As can be seen from the simulations, as far as the payload sway angle is concerned, by moving towards the polytope vertices ($\alpha = [0, 1]^T$) or close to each of

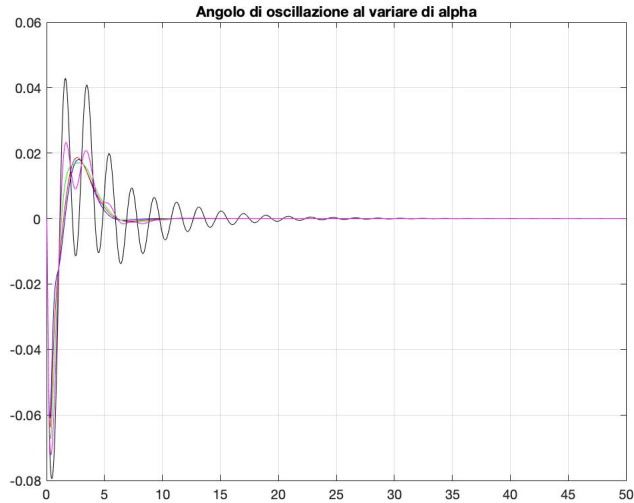

Figure 7: Payload sway angle for different values of α using null initial conditions referring to S_1 simulation.

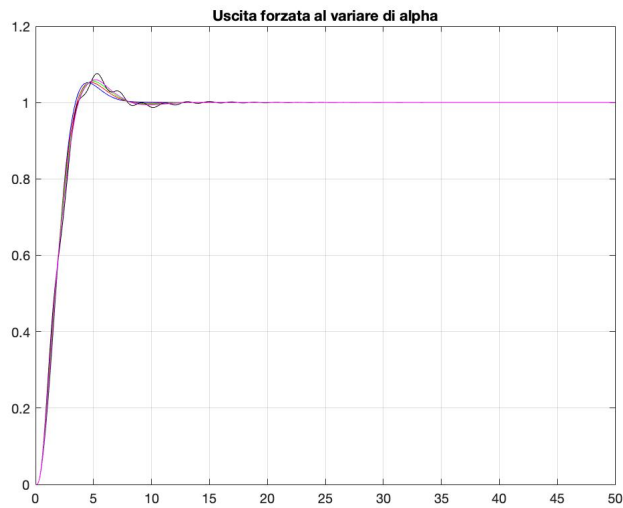

Figure 8: Controlled output $y_L(k)$ for different values of α using null initial conditions referring to S_1 simulation.

them ($\alpha = [0.2, 0.8]^T$), the transient state behavior presents evident oscillations. Looking at the controlled output it can be easily noticed that, thanks to the constant signals internal model, the unit step steady state tracking specification has been satisfied; in spite of presenting oscillations on the transient state while approaching the polytope vertices.

The sway angle and the controlled output using non-zero initial conditions ($x_3(0) = 0.001$) are depicted in Figure 9 and 10.

It is remarkable that Σ_f provides similar performances both in the case with

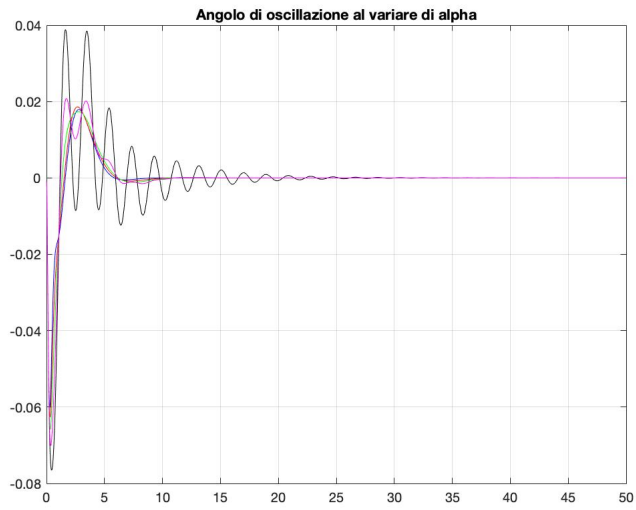

Figure 9: Payload sway angle $x_3(k)$ using different values of α with non-zero initial conditions referring to S_1 simulation.

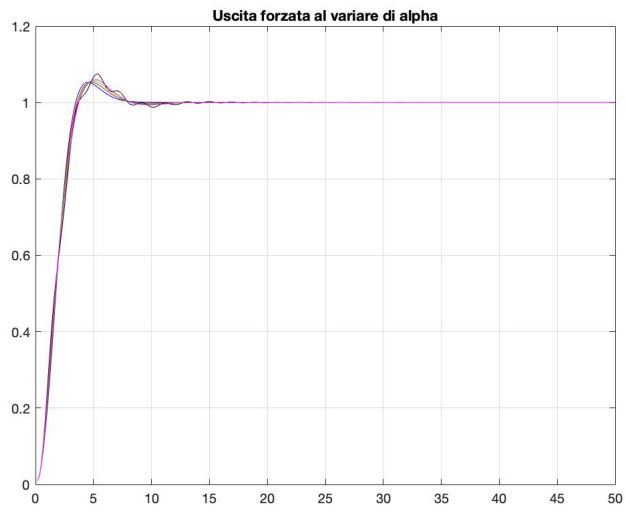

Figure 10: Controlled output $y_L(k)$ using different values of α with non-zero initial conditions referring to S_1 simulation.

null initial conditions and in the non-zero initial condition case.

4.2 Quadratic Stabilization fulfilling the constraint over the sway angle

A requirement regarding the constraint over the sway angle is introduced in this section, as aforementioned in section 3.3, assuming $\bar{x}_3 = 0.03$. Note that the parameters values hereby assumed are the same used in the previous section. In order to fulfill the specification about the constrained angle, the X invariant set will be introduced using suitable LMIs, according to section 3.4.

In this case the matrices L and \tilde{K} defining the control law are $L = (1.1176 \quad 3.8770 \quad 0.5754 \quad -0.2144)$ and $\tilde{K} = 10^8 (0.1298 \quad 0.1842 \quad 0.4421 \quad 1.8277 \quad -0.005 \quad 0 \quad 0 \quad 0 \quad 0)$. The matrix $P = Q^{-1}$ defining the invariant set $X \equiv \varepsilon(P, \gamma) = \varepsilon(Q, 1)$ for $\Sigma_f \equiv (\tilde{A}(\alpha) + \tilde{B}\tilde{K}, B_f, C_f)$ is

$$P = 10^5 \begin{pmatrix} 0.001 & -0.000 & -0.000 & -0.000 & 0.005 & 0 & 0 & 0 & 0 \\ -0.000 & 0.596 & 0.000 & -0.059 & 0.009 & 0 & 0 & 0 & 0 \\ -0.000 & 0.000 & 0.000 & -0.000 & 0.000 & 0 & 0 & 0 & 0 \\ -0.000 & -0.059 & -0.000 & 0.0059 & -0.000 & 0 & 0 & 0 & 0 \\ 0.005 & 0.009 & 0.000 & -0.0001 & 5.072 & 0 & 0 & 0 & 0 \\ 0 & 0 & 0 & 0 & 0 & 0.000 & 0.0000 & 0.00 & -0.000 \\ 0 & 0 & 0 & 0 & 0 & 0.000 & 0.000 & 0.000 & -0.000 \\ 0 & 0 & 0 & 0 & 0.000 & 0.0000 & 0.000 & 0.000 & \\ 0 & 0 & 0 & 0 & 0 & -0.000 & -0.000 & 0.000 & 0.000 \end{pmatrix}$$

The payload sway angle $x_3(k)$ and the controlled output $y_L(k)$ of Σ_f for different values of α , using null initial conditions, are depicted in Fig 11 and 12

As it can be concluded by looking at the graphics, especially at Figure 11, the optimal performance are achieved choosing $\alpha = (0.8 \quad 0.2)^T$; in fact approaching to the polytope vertices ($\alpha = (0 \quad 1)^T$) the transient state shows an oscillating behavior. Moreover, it is also derivable that the constraint requirement regarding $x_3(k)$ is satisfied: as Fig 12 shows, the sway angle is norm bounded to 0.03, so the specification

$$|x_3(k)| = \|x_3(k)\|_2 \leq \bar{x}_3$$

is satisfied. As far as the controlled output $y_L(k)$ is concerned, even in this case the presence of the internal model Σ_c grants the closed loop system Σ_f correct steady state tracking, following the unit step with no tracking error. The non-zero initial conditions (still belonging to X) case graphics, with $x_3(0) = (0.001)$ are provided in Fig. 13 and 14.

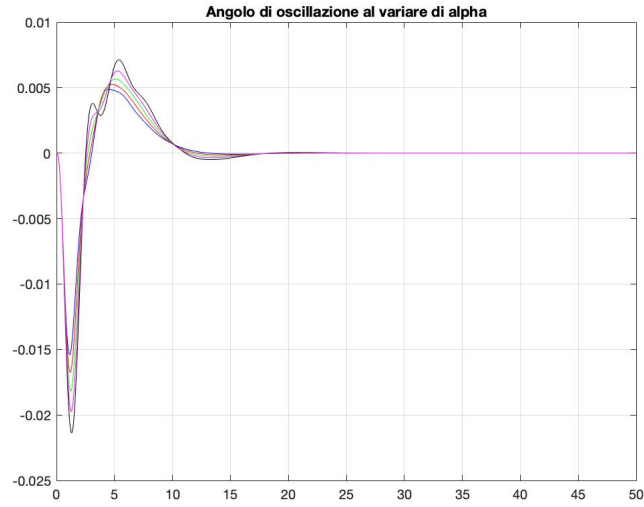

Figure 11: Payload sway angle $x_3(k)$ for many α values in the null initial conditions case, referring to S_2 simulation.

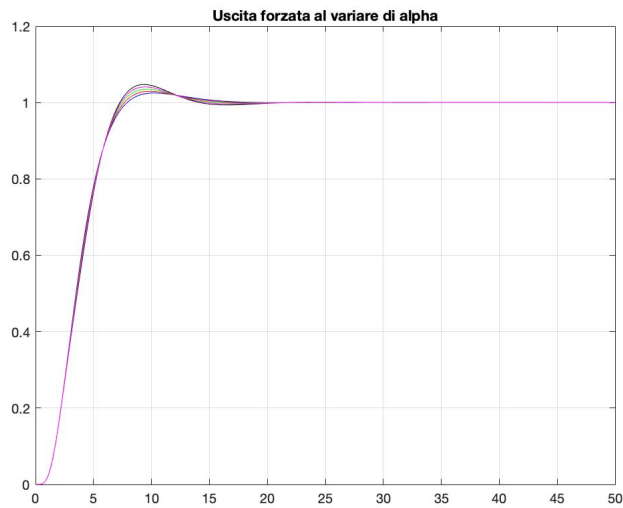

Figure 12: Forced output $y_L(k)$ for many α in the null initial conditions case, referring to S_2 simulation.

Despite the fact that the performances provided are the same, analogously with the previous case, it appears that the optimal performances are gained with $\alpha = (0.8 \ 0.2)^T$; in fact they undergo a little deterioration when approaching the polytope vertices. Even in this case the payload sway angle requirement is fulfilled, as well as the steady state tracking requirement.

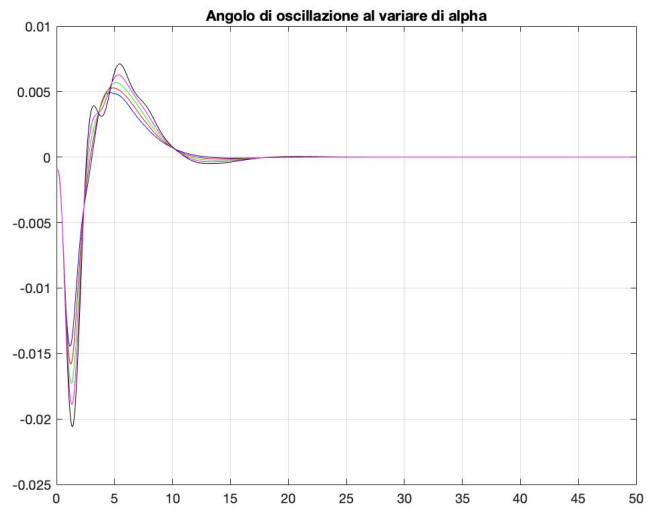

Figure 13: The sway angle $x_3(x)$ for different values of α using non-zero initial conditions, referring to S_2 simulation.

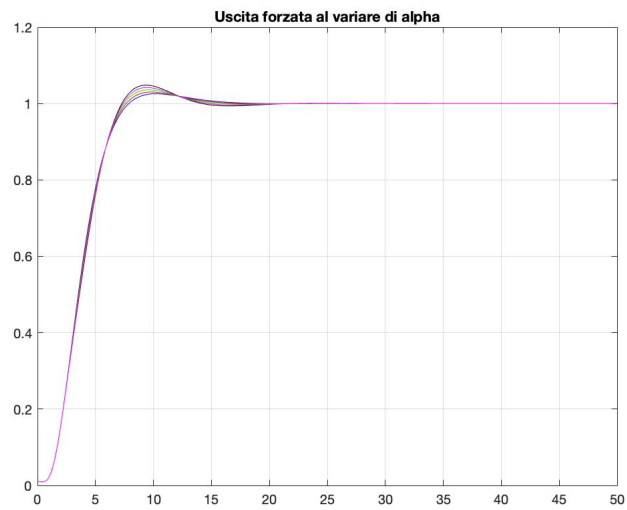

Figure 14: The forced output $y_L(k)$ for different values of α using non-zero initial conditions, referring to S_2 simulation.

4.3 Quadratic Stabilization Including the Constrained Sway Angle and the Constrained Control Effort

As disclosed before, the third simulation regards the setting of an upper bound to the control effort $u(k)$. Even in this case the parameters values assumed are the same as the previous sections. As mentioned in section 4.2, the problem is solved by introducing the suitable LMIs. The observer gain matrix L and the feedback matrix \tilde{K} of the control law are $L = (1.1176 \quad 3.8770 \quad 0.5754 \quad -0.2144)$, $\tilde{K} = 10^5 (0.2121 \quad 0.3556 \quad 0.4182 \quad 3.0061 \quad -0.0006 \quad 0 \quad 0 \quad 0 \quad 0)^T$.

The matrix $P = Q^{-1}$ defining the invariant set $X = \varepsilon(P, 1)$ for $\Sigma_f \equiv (\tilde{A}(\alpha) + \tilde{B}\tilde{K}, B_f, C_f)$ is

$$P = 10^5 \begin{pmatrix} 0.001 & -0.000 & -0.000 & -0.000 & 0.0065 & 0 & 0 & 0 & 0 & 0 \\ -0.000 & 0.001 & 0.000 & 0.000 & -0.000 & 0.005 & 0 & 0 & 0 & 0 \\ -0.000 & 0.000 & 0.000 & -0.000 & 0.000 & 0 & 0 & 0 & 0 & 0 \\ -0.000 & -0.000 & -0.000 & 0.000 & -0.000 & 0 & 0 & 0 & 0 & 0 \\ 0.006 & 0.004 & 0.000 & -0.000 & 4.230 & 0 & 0 & 0 & 0 & 0 \\ 0 & 0 & 0 & 0 & 0 & 0.000 & 0.000 & 0.000 & -0.000 & 0 \\ 0 & 0 & 0 & 0 & 0 & 0.000 & 0.000 & 0.000 & -0.000 & 0 \\ 0 & 0 & 0 & 0 & 0 & -0.000 & -0.000 & 0.000 & 0.000 & 0 \\ 0 & 0 & 0 & 0 & 0 & -0.000 & -0.000 & 0.000 & 0.000 & 0 \end{pmatrix}$$

The specification this sections aims to add concerns the norm bounded control effort. Fig. 15 and 16 depict the control effort $u(k)$ behavior before setting the constraint:

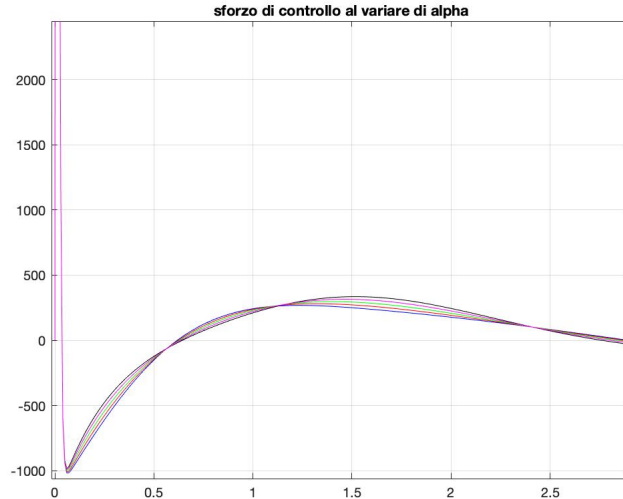

Figure 15: The control effort $u(k)$ for Σ_f for different values of α referring to S_2 simulation, with null inicial conditions

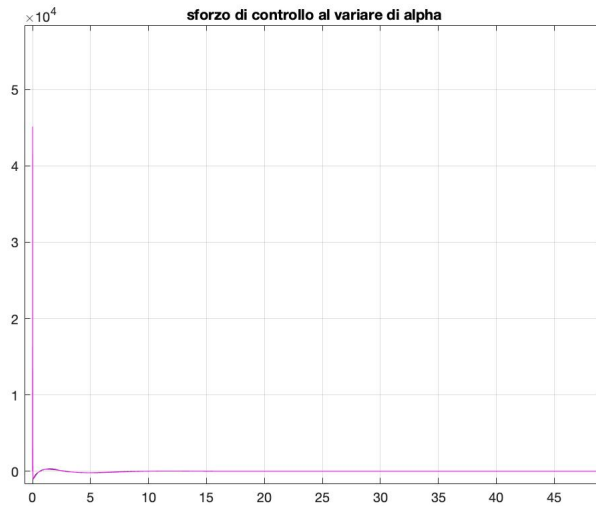

Figure 16: The control effort $u(k)$ for Σ_f for different values of α referring to S_2 simulation, with null initial conditions

According to what said before, in order to satisfy the norm bounded control effort requirement, it is needed to satisfy the condition:

$$\|u\|_2 \leq u_{max}$$

Where it has been chosen to use $u_{max} = 700$ as a suitable upper bound. Analogously to the previous cases, the numerical simulations have been computed using both null initial conditions and non-zero initial conditions, still in the invariant set. Fig. 17 depicts the control effort $u(k)$ after norm bounding it.

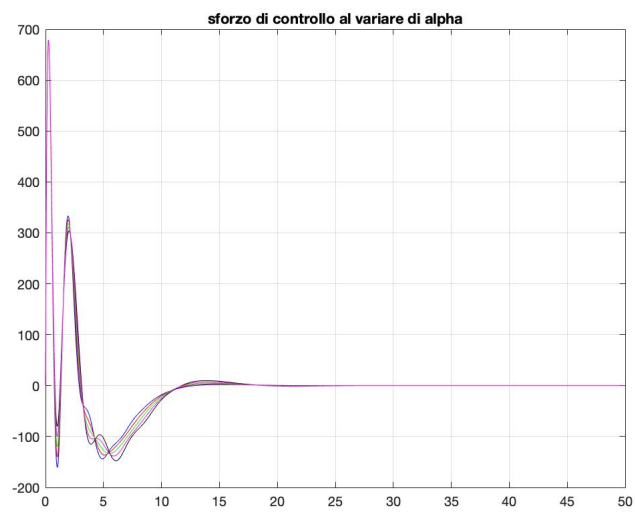

Figure 17: The norm bounded control effort $u(k)$ for different values of α , referring to S_3 simulation with null initial conditions.

As far as the non-zero initial conditions $(x_f(0)^T = (0 \ 0 \ 0 \ 0 \ 0 \ 0 \ 0 \ 0.001 \ 0)^T)$ simulations are concerned, Fig. 18 depicts the norm bounded $u(k)$ for different values of α :

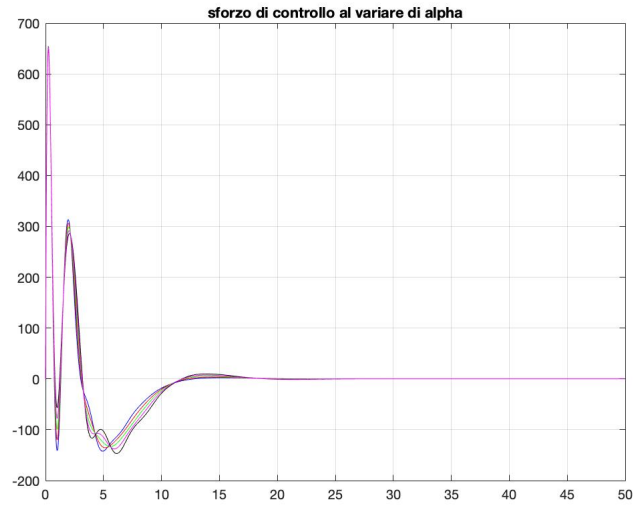

Figure 18: Norm bounded control effort $u(k)$ for different values of α and non-zero initial conditions, referring to S_3 simulation

It is evident that the control effort behavior is the same both in the null initial conditions and in the non-zero initial conditions; moreover, as Fig 17 and 18 show, the constraint requirement is satisfied: the control effort $u(k)$ is norm bounded to 700, as it shows a similar behavior for all of the α values hereby considered. To conclude this last simulation, the following Fig. 19 and Fig. 20 depict respectively the sway angle and the controlled output:

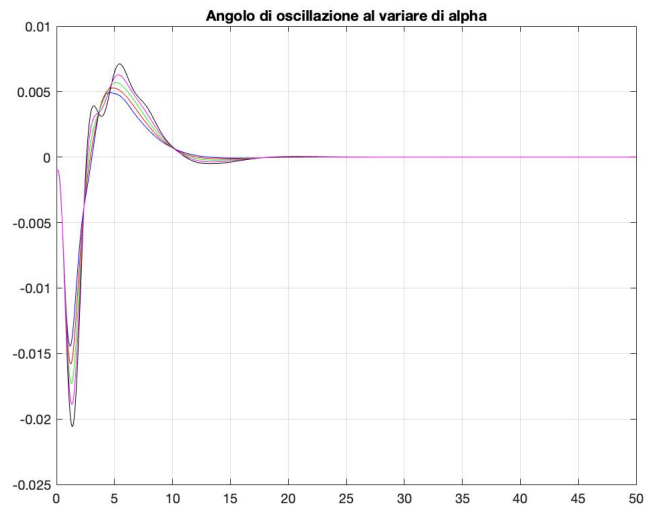

Figure 19: Sway angle for different values of α and non-zero initial conditions, referring to S_3 simulation.

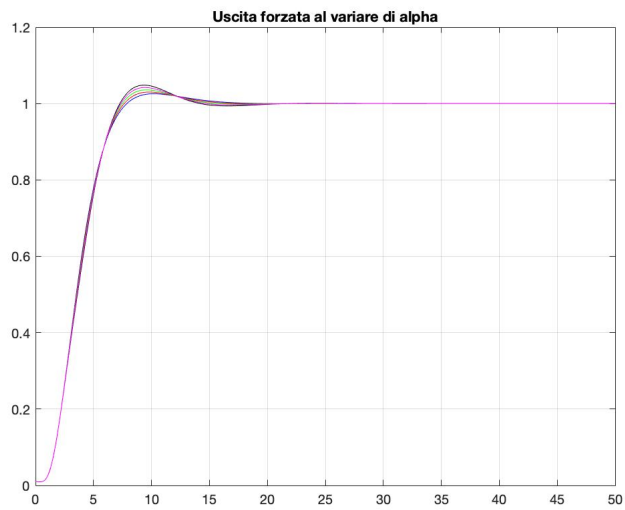

Figure 20: The controlled output for different values of α and non-zero initial conditions, referring to S_3 simulation.

5 Conclusions

In the hereby presented thesis the Gantry Crane control problem has been solved introducing a control strategy easily implementable, with the advantages both in terms of the cost, not requiring additional sensors to get the sway angle and velocity signals measurements. Such strategy is based to the linearized gantry crane model and takes into account uncertainties on the payload value. The numerical results also prove the approach worthy, showing the fulfillment of each specification. To sum up, the satisfying result of the simulations regarding non-zero initial conditions demonstrates the approach versatility even with an initial misalignment between the cart and the payload.

Special Thanks

Arrived to such an important step, I'd like to thank everyone helped me achieving this important goal.

First of all, I'd like to thank the Professor Valentina Orsini, who it has been an honor and a pleasure having as a supervisor, as well as my co-supervisor Professor Leopoldo Jetto.

Moreover, a special thank to everyone who supported me during these years of personal and academic growth, especially my family and my friends.

References

1. H. Shingin, Y. Ohta, Optimal Invariant Sets for Discrete-time Systems: Approximation of Reachable Sets for Bounded Inputs, in: IFAC Proceeding Volumes, 2004, pp 389-394;
2. A. Luca, P. Rodriguez, D. Dumur, Invariant Sets Method for State-Feedback Control Design, in: 17th Telecommunications forum TELFOR, 2009, pp 681-684;
3. A. Luca, P. Rodriguez, D. Dumur, Youla-Kucˇera parameter synthesis using invariant sets techniques, in: 2010 American Control Conference Marriott Waterfront, Baltimore, MD, USA June 30-July 02, 2010, pp 5626-5631;
4. L. Ramli, Z. Mohamed, A.M.Abdullahi, H.I.Jaafar, I.M.Lazim, Control Strategies for Crane Systems: A Comprehensive Review, in Mechanical Systems and Signal Processing, Volume 95, October 2017, Pages 1-23;
5. L. Jetto, V. Orsini, A Robust Least Square Based Approach To Min-Max Model Predictive Control, in International Journal of Robust and Nonlinear Control, 2020, pp 1-32;
6. L. Jetto, V.Orsini, An optimally combined feedback/feedforward control architecture for minimizing the oscillations in the fast response of a gantry crane control system, in: 2021 29th Mediterranean Conference on Control and Automation (MED), 2021, pp 1-8.